



# XP Series-Ultra High Rate

## XP12-400(12V400W)



### Specifications

Rated Voltage	12V	
Nominal Rate ( $W_{15}, 1.67V/cell$ )	422W/cell	
Nominal Capacity( $C_{20}, 1.80V/cell$ )	101.6Ah	
Dimension	Length	325.5±2mm (12.8 inches)
	Width	170±2mm (6.69 inches)
	Container Height	213±2mm (8.39 inches)
	Total Height	216±2mm (8.50 inches)
Approx. Weight	31.6 Kg (69.7 lbs)	
Terminal	M6	
Container Material	ABS	
Rated Capacity (25°C)	101.6 Ah	(20hr, 5.08A, 1.80V/cell)
	96.0 Ah	(10hr, 9.60A, 1.80V/cell)
	89.5 Ah	(5hr, 17.9A, 1.75V/cell)
	80.4 Ah	(3hr, 26.8A, 1.75V/cell)
	69.5 Ah	(1hr, 69.5A, 1.67V/cell)
Max. Discharge Current	1655A	
Internal Resistance (25°C)	Approx. 3.6mΩ	
Operating Temp. Range	Discharge	-15 ~ 50°C (5 ~ 122°F)
	Charge	-20 ~ 40°C (-4 ~ 104°F)
	Storage	-15 ~ 40°C (5 ~ 104°F)
Nominal Operating Temp. Range	25±3°C (77±5°F)	
Max. Charging Current(25°C)	30.0A	
Charge voltage(25°C)	Float	13.5V
	Temp. Coefficient	-3mV/cell/°C
	Equalization	14.1~14.4V
Effect of temp. to Capacity	40°C (104°F)	103%
	25°C (77°F)	100%
	0°C (32°F)	86%
Self Discharge	≤3%/month @ 25°C	



### Layout

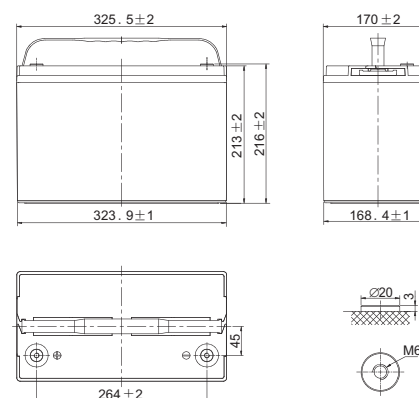

### Constant Current Discharge (Amperes) at 25 °C (77°F)

F.V/Time	5min	10min	15min	20min	30min	45min	1h	2h	3h	4h	5h	6h	8h	10h	20h
1.85V/cell	244.7	193.8	168.2	139.3	107.2	78.0	58.4	33.8	25.0	20.0	16.8	14.6	11.4	9.37	4.94
1.80V/cell	290.9	220.9	186.4	152.0	114.8	82.3	61.5	35.2	26.0	20.8	17.5	15.0	11.7	9.60	5.08
1.75V/cell	327.2	243.0	200.9	161.7	121.8	86.1	65.1	36.5	26.8	21.4	17.9	15.4	12.0	9.81	5.20
1.70V/cell	357.7	258.7	211.8	169.6	126.7	89.8	67.8	37.9	27.6	21.9	18.2	15.7	12.2	10.0	5.26
1.67V/cell	391.3	274.3	222.6	171.8	129.4	91.1	69.5	39.0	28.4	22.5	18.7	16.1	12.5	10.1	5.30
1.60V/cell	410.1	285.9	229.4	181.8	133.8	94.1	72.4	39.7	28.9	22.8	18.9	16.3	12.6	10.3	5.33

### Constant Power Discharge (Watts/cell) at 25 °C (77°F)

F.V/Time	5min	10min	15min	20min	30min	45min	1h	2h	3h	4h	5h	6h	8h	10h	20h
1.85V/cell	476.2	379.1	330.9	275.3	213.1	155.8	117.0	68.1	50.4	40.6	34.2	29.7	23.4	19.3	10.2
1.80V/cell	559.9	427.7	363.0	297.7	226.2	163.0	122.4	70.4	52.2	41.9	35.3	30.5	23.9	19.7	10.4
1.75V/cell	623.5	466.1	387.8	313.9	237.8	169.2	128.6	72.5	53.4	42.9	35.9	31.1	24.4	20.0	10.6
1.70V/cell	673.9	490.7	404.0	325.8	244.9	174.9	133.0	74.7	54.8	43.6	36.4	31.4	24.6	20.2	10.7
1.67V/cell	731.1	516.5	422.0	328.0	248.8	176.3	135.4	76.5	55.9	44.5	37.2	32.0	25.0	20.4	10.7
1.60V/cell	757.7	532.5	430.4	343.7	254.8	180.4	139.9	77.1	56.5	44.8	37.3	32.2	25.0	20.4	10.7



# XP Series-Ultra High Rate

## XP12-400(12V400W)



### Applications

- UPS
- Hospitals & Testing Laboratories
- Emergency Power Supply
- Electric starting
- Telecommunications
- Data Centers

### General Features

- Special designed grids for optimized high power density
- Oversized partition intercell welds, providing low resistance connections & minimal power loss
- Advanced lead tin calcium alloy, reduces grid corrosion & promotes long battery life
- Performance excels at high rates of discharge & recharge
- High integrity post seal for long life

### Standards

- Compliance with IEC 60896 standards
- Classified as "Long Life" according to Eurobat
- CE, UL Certified
- Manufactured in Leoch® IATF16949, OHSAS 18001, ISO 9001 and ISO 14001 certified production facilities

### Discharge Characteristics

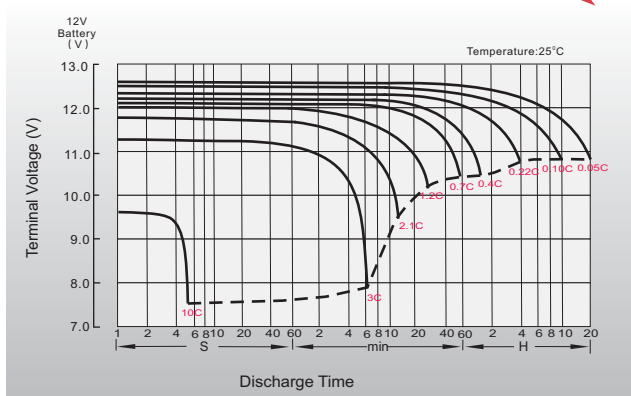

### Float Charging Characteristics

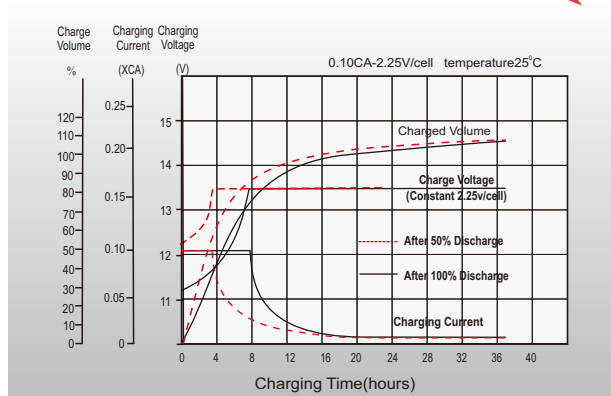

### Self Discharge Characteristics

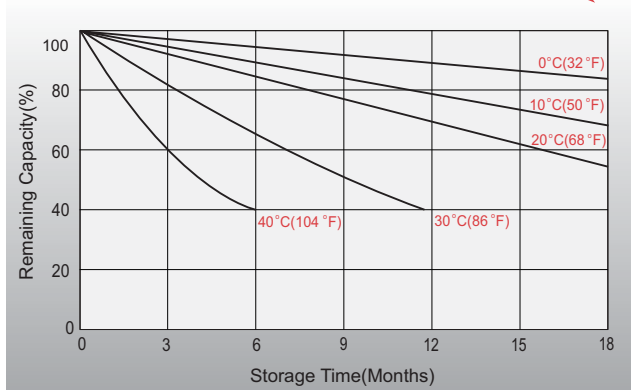

### Effect of Temperature on Long Term Float Life

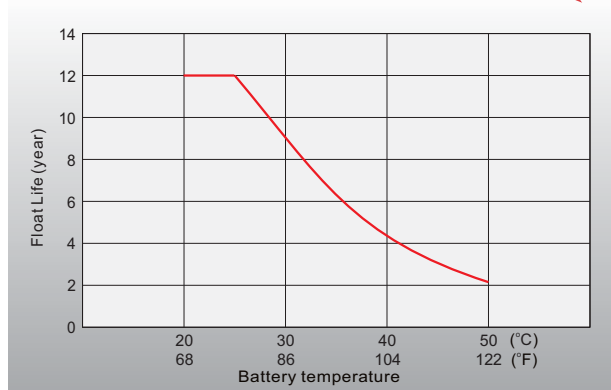

## Sales Offices Worldwide

#### China Sales Office

5th Floor, Xinbaohui Bldg., Nanhai Blvd.,  
Nanshan, Shenzhen, China. 518052  
Tel: +86-755-86036060 (100 lines)  
Fax: +86-755-26067269  
E-mail: export@leoch.com

#### HongKong Sales Office

Workshop C, 33/F, TML Tower, No. 3 Hoi Shing Road,  
Tsuen Wan, New Territories, Hong Kong  
Tel: +852 35786666  
Fax: +44 1452 690125  
E-mail: sales.hk@leoch.com

#### Singapore Sales Office

No. 1 Tech Park Crescent,  
Singapore 638131  
Tel: +65 68636078  
Fax: +65 6863 6079  
Email: sales.sg@Leoch.com

#### Australia Sales Office

2 /29 Tarlington Place, Smithfield. NSW 2164  
Australia  
Tel: 02 9756 0950  
E-mail: sales.au@leoch.com

#### North America Sales Office

19751 Descartes  
Foothill Ranch, CA 92610, USA  
Tel: 949-588-5853  
Fax: 949-588-5966  
E-mail: sales@leoch.us  
Http:// www.leoch.us

#### UK Sales Office

9B Wheatstone Court. Waterwells, Business Park,  
Gloucester, GL2-2AQ, UK United Kingdom  
Tel: +44(0) 1452 729428 / 1452 729696  
Fax: +44 1452 690125  
E-mail: Sales.Europe@leoch.com  
Http:// www.leoch.eu

#### EMEA Sales Office

1 Deligiorgi St., 121 31 Athens,  
Greece  
Tel: +30 210 5760318 (2 lines)  
E-mail: support\_EMEA@leoch.com  
Http:// www.leoch.eu

#### India Sales Office

Shed no.A-53(b), 2nd Stage of Peenya Industrial Area,  
Bangalore North Taluk, Bangalore-560058, India  
Tel: +91-80-23440018/23440019  
Fax: +91-80-23440017  
E-mail: indiasales@leoch.com



[Http://www.leoch.com](http://www.leoch.com)

© 2022 LEOCH. All rights reserved.

Trademarks and logos are the property of LEOCH and its affiliates unless otherwise noted.  
Subject to revisions without prior notice.

Publication No.: LB-XP12-400-PD-EN-V1.4-202204